

Two Tiers Decorative Pendant

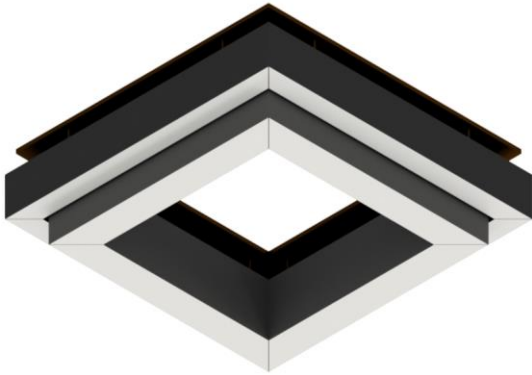

Features

Teslyte PD-96 series is a two tiers decorative pendant that has 3-Form Hush Natural Viria Ecoresin Sandstone Acrylic wrapped on all sides and frosted clear acrylic at the bottoms. This decorative pendant with 3-Form material enhances to any large indoor spaces like ballroom, dining hall and convention hall.

- Housing/Lens:
 - 3 Form Hush Natural Varia Ecoresin Sandstone FO1 on all sides (inside and outside)
 - Frosted Clear Acrylic at the bottom
- LEDs
 - Integral highly efficient LED module driver
 - 350 lumens per foot
- Mechanical dimensions
 - 96" L x 96" W x 30" H
 - 96" L x 180" W x 30" H
- Application: Commercial indoor
- Warranty:
 - UL listed
 - 5 years warranty

Ordering Information

Product code	Voltage	Distribution	Wattage	CCT (K)	Finish	Optional
PD-96XX	U	S	350LM1	35	3FSS	N
XX: 96 - 96"x96" 180 - 96"x180"	U - Univ. (120 - 277 Vac)	S - Symmetrical	350LM1 – Wattage 350 lumens per foot	35 - 3500K	3FSS – 3 Form Sandstone FO1	N - No option

Note: Fixtures must be grounded in accordance with national, state, and/or local electrical codes. Failure to do so may result in serious personal injury

Mechanical Dimensions

PD-9696: 96" x 96" dimension

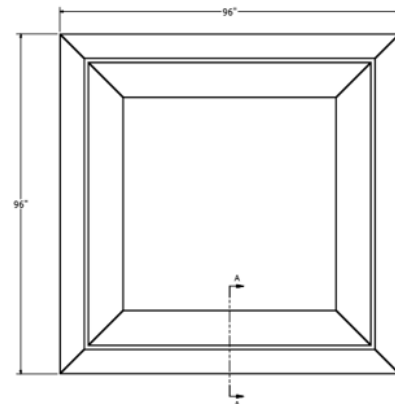
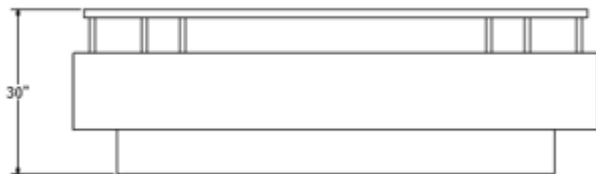

PD-9696: 96" x 180" dimension

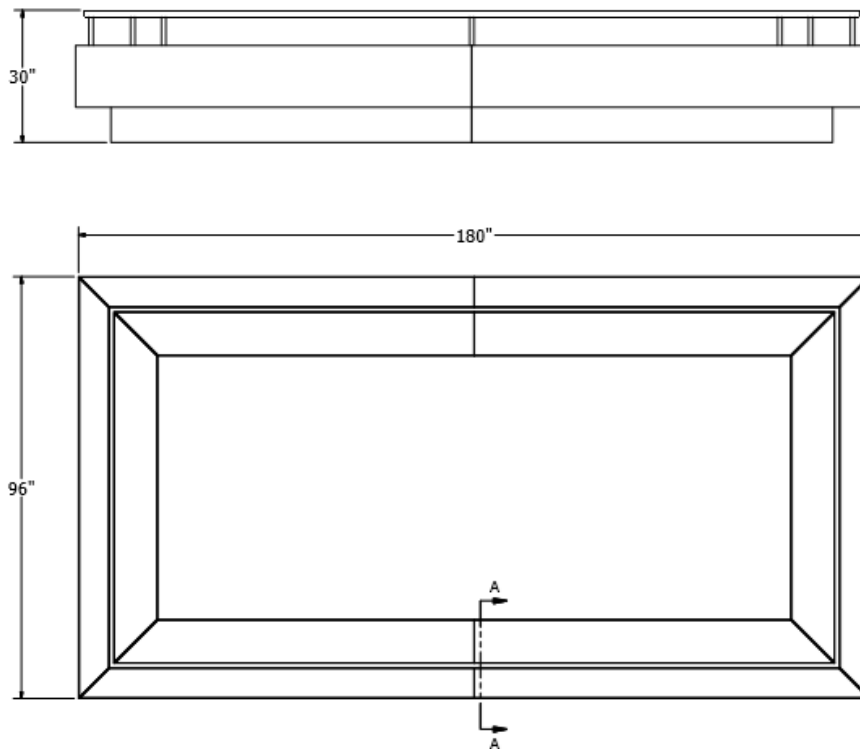

Cross section

